

YASKAWA

New Generation Robots MOTOMAN-SDA, SIA Series



Certified for
ISO9001 and
ISO14001



JAB
QMS Accreditation
R009



JQA-0813



JQA-EM0202

New Generation Robots to Enrich Our Futures

Dual-arm Robot

Slim body and arms for easy installation in the same space as human workers

The SDA dual-arm robot is designed to resemble a human figure.

The robot has slim arms that are the same size as a human's arms and seven joints in each arm.

Manual work can be automated without changing the existing layout of the facility because of the robot's human-like size.

The coordinated operation of 15 axes (seven axes for each arm and one at waist) allows the robot to move efficiently with greater dexterity and eliminates the need for specialized facilities for the robot.

1. Human-like size and performance

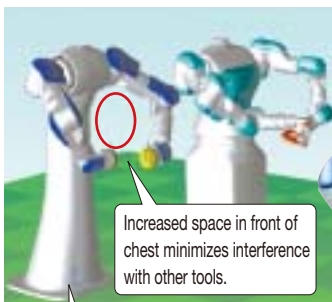

Broadened range of applications with slim body and 7-axis arms

2. Versatility

- Holding of workpieces with both arms
- Positioning
- Freely transfer workpieces from one arm to the other
- Independent control

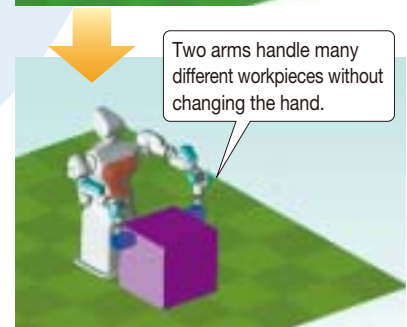
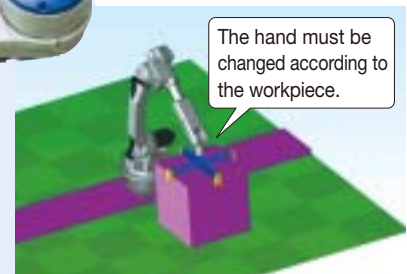

3. Internal user I/O wiring harness and air lines

Besides eliminating peripheral interference, the SDA also enables complete offline simulation.



Product Line Dual-arm Robot



MOTOMAN-SDA5D/F
Payload: 5 kg/arm (10 kg/dual arms)



MOTOMAN-SDA10D/F
Payload: 10 kg/arm (20 kg/dual arms)



MOTOMAN-SDA20D/F
Payload: 20 kg/arm (40 kg/dual arms)

MOTOMAN leads the way in the new era and consistently offers new solutions to improve and to enhance the efficiency and quality of production lines. The MOTOMAN-SDA and -SIA series are new generation robots with unconventional robot forms (dual-arm and 7-axis single-arm) and human-like movements that are changing the relationship between humans and robots and the concept of manufacturing. Now is the beginning of a new future that transcends our imaginations.

**7-axis
Single-arm
Robot**

Slim arm for flexible movements in narrow spaces

The SIA single-arm robot resembles a human arm. With seven joints like a human arm, the SIA robot has a high degree of freedom and it can bend, twist, or extend itself even in narrow spaces. This enables a space-saving, high-density layout.

1. Space-saving and high-density layout

Installation in narrow spaces between machines is now possible. Optimal for high-density layouts.

7-axis robot requires less space than 6-axis robot.

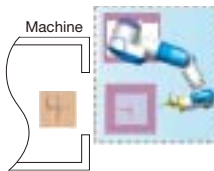

Installation example of 7-axis robot

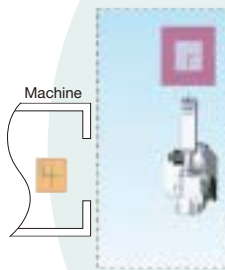

Installation example of 6-axis robot

3. Internal user I/O wiring harness and air lines

Besides eliminating peripheral interference, the SIA also enables complete offline simulation.

2. Flexibility

- Elbow movement (unique and unprecedented feature in the industry)

The 7-axis configuration has enabled the angle of the elbow to be changed without affecting the tool position or posture.

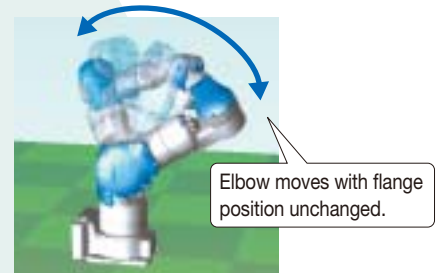

- Flexible reach (to rear of workpiece)

The arm's flexibility enables the SIA robot to be installed in high-density layout without interference and to enter narrow spaces inaccessible to humans.

- Many installation options

The SIA robot can be installed in many ways without affecting functionality: on the floor, wall, ceiling, or slope.



Product Line 7-axis Single-arm Robot



MOTOMAN-SIA5D/F
Payload: 5 kg



MOTOMAN-SIA10D/F
Payload: 10 kg



MOTOMAN-SIA20D/F
Payload: 20 kg



MOTOMAN-SIA30D
Payload: 30 kg



MOTOMAN-SIA50D
Payload: 50 kg

New MOTOMAN Designs and Applications

Designed to Reduce Human Workload for Better Labor Conditions & Pursuit of Human-Robot Coexistence

Applications

Dual-arm Robot



Improvement on Logistic process

- Handling parts with dual arm gripping action
- Continuous handling without a temporary stand or a reverse jig
- Distribution of parts for each process

Improvement on Assembling process

- Jigless assembly with dual arms
- Jigless positioning with dual arms
- High-accuracy assembly with high-speed, high-precision movements

Assembly of Automobile Engine



Sorting with Returnable Cases



Distributing of Parts



Assembly and Testing



Coordinated Operation with Welding Robot



Other Applications

- Assembly of LCD panels
- Assembly of electrical appliances/lighting
- Assembly of cable harnesses
- Handling, turning, and assembly of automotive parts
- Handling of lengthy automotive parts
- Transfer of beverage packs
- Transfer of returnable cases in containers

Technical Consulting

For more information on how to introduce the new generation robots into your system, contact your nearest Yaskawa representative.

7-axis Single-arm Robot



Improvement on Logistic process

- Installation in narrow spaces between machines
- Reach into narrow spaces
- Lifting operation (from below)

Improvement on Assembling process

- Assembly in high-density layout of robots
- Coordinated assembling operation of several robots without interference

Attachment and Removal of Workpieces for NC Machines



Assembly with 7-axis Robots in High-Density Layout

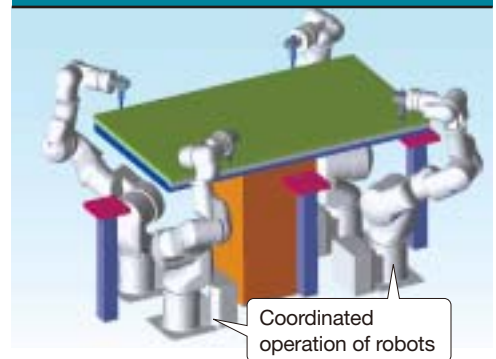

Handling between Machines in Limited Spaces (Wraparound movement)

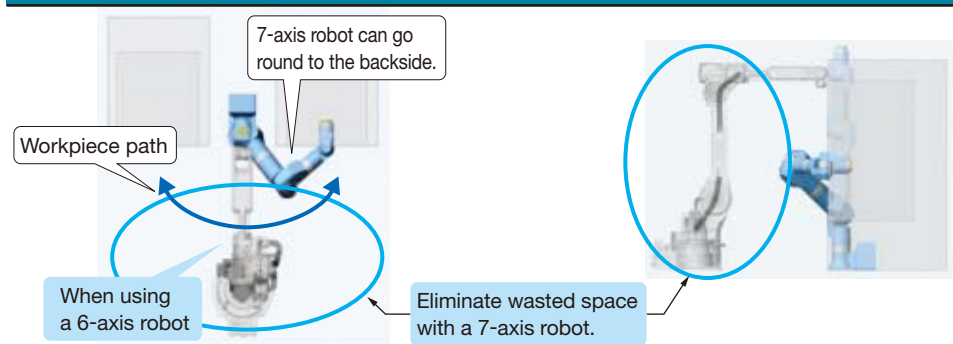

Transfer of Workpieces

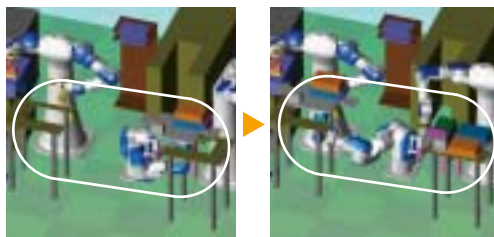

Example 1: Transfer workpieces from right to left with only a single-arm robot

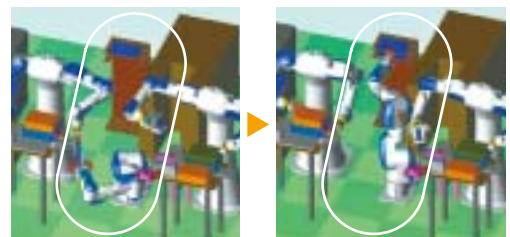

Example 2: Transfer workpieces from front to rear in minimal space

Technical Consulting

For more information on how to introduce the new generation robots into your system, contact your nearest Yaskawa representative.

Dual-arm Robot

MOTOMAN-SDA5D/F



Dual-arm 15 axes Payload: 5 kg/arm (10 kg/dual arms)

The MOTOMAN-SDA5D/F is a dual-arm robot with a 5 kg payload per arm (dual arm: 10 kg).

For small parts assembly and handling applications, this robot allows a more compact facility layout.

Features

- The arms have been slimmed by employing a newly-developed miniaturized actuator for the wrist section, which comes closest to the parts and products. This has greatly reduced the interference of the arms with parts and products as well as interference between the two arms themselves.
- With a repetitive positioning accuracy of ± 0.06 mm, the robot is ideal for small parts assembly processes that require delicate work to be performed with high accuracy.
- The maximum range of motion can be maintained using an ingenious mechanism for the arm joints that prevents the range of motion from being restricted even when downsizing robots.

Dimensions Units: mm

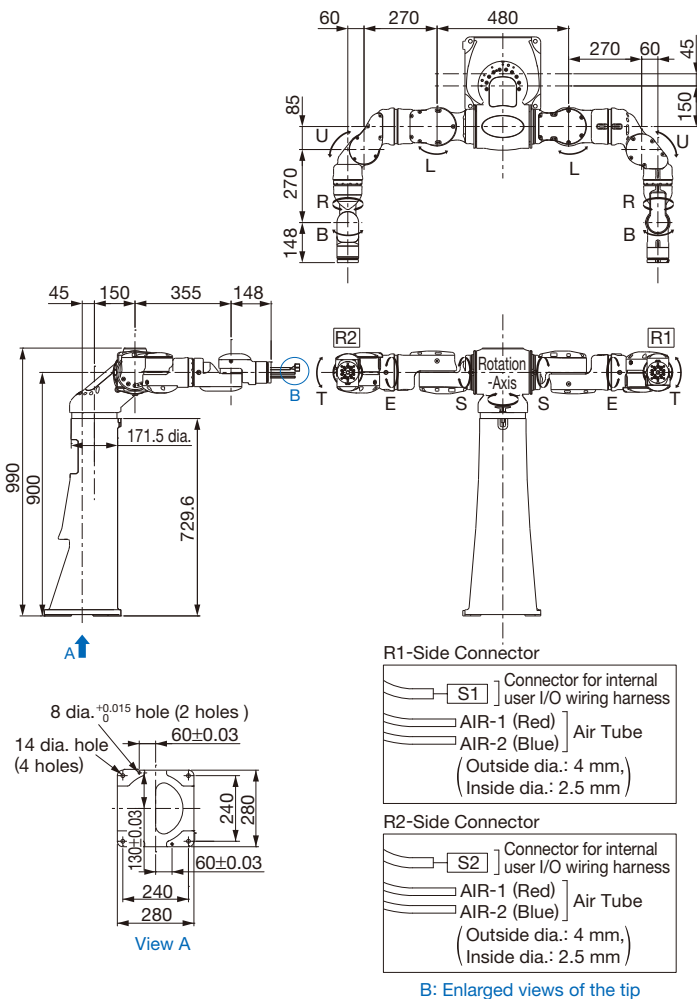

Manipulator Specifications

Model	MOTOMAN-SDA5D/F*3	
Controlled Axis	15 (Articulated) [7 axes for left arm (R1), 7 axes for right arm (R2), 1 rotary axis]	
Payload	5 kg/arm	
Repeatability*1	± 0.06 mm	
Range of Motion	Rotation	$-170^\circ - +170^\circ$
	S-axis (lifting)	R1 : $-90^\circ - +270^\circ$, R2 : $-270^\circ - +90^\circ$
	L-axis (lower arm)	$-110^\circ - +110^\circ$
	E-axis (elbow twist)	$-170^\circ - +170^\circ$
	U-axis (upper arm)	$-90^\circ - +115^\circ$
	R-axis (upper arm twist)	$-180^\circ - +180^\circ$
	B-axis (wrist pitch/yaw)	$-110^\circ - +110^\circ$
	T-axis (wrist twist)	$-180^\circ - +180^\circ$
Maximum Speed	Rotation	3.14 rad/s, 180°/s
	S-axis (lifting)	3.49 rad/s, 200°/s
	L-axis (lower arm)	3.49 rad/s, 200°/s
	E-axis (elbow twist)	3.49 rad/s, 200°/s
	U-axis (upper arm)	3.49 rad/s, 200°/s
	R-axis (upper arm twist)	3.49 rad/s, 200°/s
	B-axis (wrist pitch/yaw)	4.01 rad/s, 230°/s
T-axis (wrist twist)	6.11 rad/s, 350°/s	
Allowable Moment	R-axis (upper arm twist)	14.7 N · m
	B-axis (wrist pitch/yaw)	14.7 N · m
	T-axis (wrist twist)	7.35 N · m
Allowable Inertia (GD ² /4)	R-axis (upper arm twist)	0.45 kg · m ²
	B-axis (wrist pitch/yaw)	0.45 kg · m ²
	T-axis (wrist twist)	0.11 kg · m ²
Approx. Mass	110 kg	
Power Requirements*2	2.0 kVA*4	
Ambient Conditions	Temperature	0°C to +40°C
	Humidity	20% to 80%RH(non-condensing)
	Vibration	Less than 4.9 m/s ²
	Others	<ul style="list-style-type: none"> • Free from corrosive gas or liquid, or explosive gas or liquid • Free from exposure to water, oil or dust • Free from excessive electrical noise (plasma)

*1 : Conforms to ISO 9283.

*2 : Varies in accordance with applications and motion patterns.

*3 : The letter "F" at the end of the model number indicates that an FS100 controller is used to control the robot. When a DX100 controller is used, the model number will have the letter "D" at the end.

*4 : SDA5F requires 1.5 kVA.

Note : SI units are used for the specifications.

MOTOMAN-SDA10D/F



A built-in crystal sensor type is also available
For details, refer to the KAEP C940440 26 catalog

■ Dimensions Units: mm

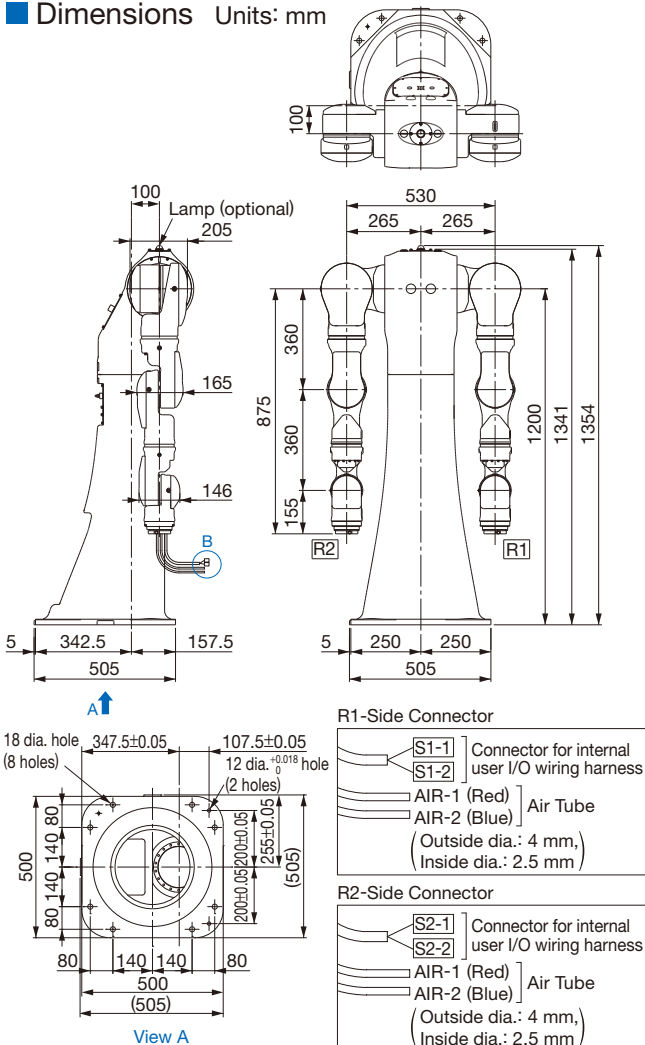

Dual-arm (15 axes) Payload: 10 kg/arm (20 kg/dual arms)

The MOTOMAN-SDA10D/F is human-sized and has two 7-axis arms that enable human-like movements.

Capable of assembling and handling heavy objects up to 10 kg per arm (dual arm: 20 kg). Can be easily installed in existing production lines without changing the layout because of the robot's human-like size.

Features

- Same level of capability as a human in assembling and handling heavy objects.
- Human-like flexibility of motions achieved by having two arms with 7 axes each and a rotary axis at the waist.
- High-precision movement for accuracy.
- Enhanced acceleration performance for reduced operating time.
- Independent control and operation of two arms for higher efficiency.
- Keep costs low as the two arms can transfer workpieces from arm to arm and turn them without using a temporary stand or a reverse jig.

■ Manipulator Specifications

Model	MOTOMAN-SDA10D/F*3		
Controlled Axis	15 (Articulated) [7 axes for left arm (R1), 7 axes for right arm (R2), 1 rotary axis]		
Payload	10 kg/arm		
Repeatability*1	±0.1 mm		
Range of Motion	R1 · R2	Rotation	-170° - +170°
		S-axis (lifting)	-180° - +180°
		L-axis (lower arm)	-110° - +110°
		E-axis (elbow twist)	-170° - +170°
		U-axis (upper arm)	-135° - +135°
		R-axis (upper arm twist)	-180° - +180°
		B-axis (wrist pitch/yaw)	-110° - +110°
Maximum Speed	R1 · R2	Rotation	2.27 rad/s, 130°/s
		S-axis (lifting)	2.97 rad/s, 170°/s
		L-axis (lower arm)	2.97 rad/s, 170°/s
		E-axis (elbow twist)	2.97 rad/s, 170°/s
		U-axis (upper arm)	2.97 rad/s, 170°/s
		R-axis (upper arm twist)	3.49 rad/s, 200°/s
		B-axis (wrist pitch/yaw)	3.49 rad/s, 200°/s
Allowable Moment	R-axis (upper arm twist)	T-axis (wrist twist)	31.4 N · m
		B-axis (wrist pitch/yaw)	31.4 N · m
		T-axis (wrist twist)	19.6 N · m
Allowable Inertia (GD ² /4)	R-axis (upper arm twist)	B-axis (wrist pitch/yaw)	1.0 kg · m ²
		B-axis (wrist pitch/yaw)	1.0 kg · m ²
		T-axis (wrist twist)	0.4 kg · m ²
Approx. Mass	220 kg		
Power Requirements*2	2.5 kVA*4		
Ambient Conditions	Temperature	0°C to +40°C	
	Humidity	20% to 80%RH(non-condensing)	
	Vibration	Less than 4.9 m/s ²	
Others	<ul style="list-style-type: none"> • Free from corrosive gas or liquid, or explosive gas or liquid • Free from exposure to water, oil or dust • Free from excessive electrical noise (plasma) 		

*1 : Conforms to ISO 9283.

*2 : Varies in accordance with applications and motion patterns.

*3 : The letter "F" at the end of the model number indicates that an FS100 controller is used to control the robot. When a DX100 controller is used, the model number will have the letter "D" at the end.

*4 : SDA10F requires 2.0 kVA.

Note : SI units are used for the specifications.

Dual-arm Robot

MOTOMAN-SDA20D/F



Dual-arm 15 axes Payload: 20 kg/arm (40 kg/dual arms)

The MOTOMAN-SDA20D/F is a high-payload robot that is capable of handling heavy objects up to 20 kg per arm (dual arm: 40 kg).

Same as the SDA10D/F, the SDA20D/F has fifteen controlled axes and realizes human-like flexibility of movement.

Features

- Handling of heavy objects up to 20 kg per arm (dual arm: 40 kg).
- High-speed and high-precision operation.
- Human-like flexibility of motions achieved by having two arms with 7 axes each and a rotary axis at the waist.
- The design of the hands can be simplified even when holding large objects since the robot can carry workpieces using both arms.

Dimensions Units: mm

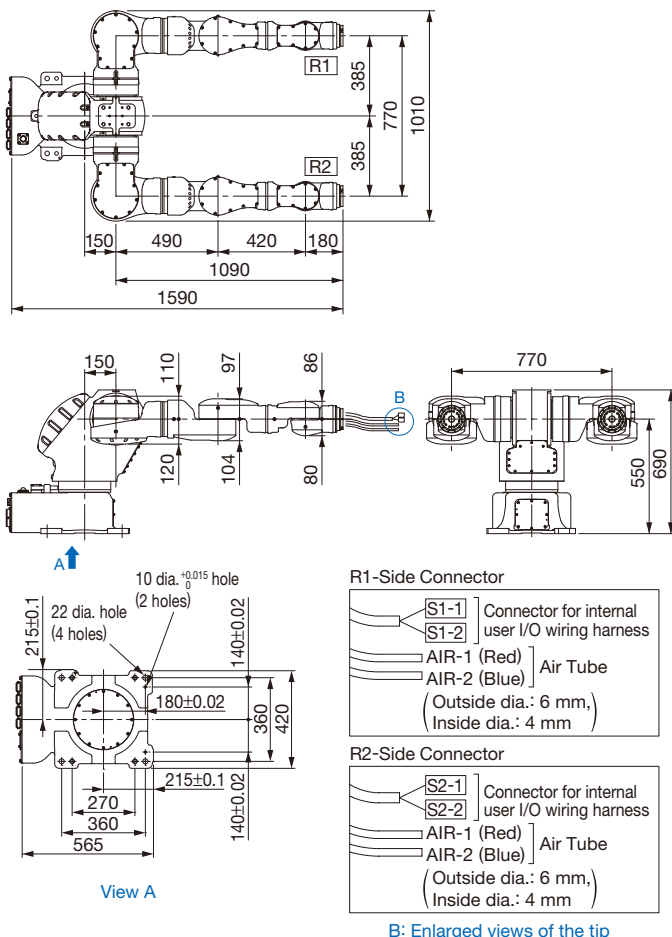

Manipulator Specifications

Model	MOTOMAN-SDA20D/F*3		
Controlled Axis	15 (Articulated) [7 axes for left arm (R1), 7 axes for right arm (R2), 1 rotary axis]		
Payload	20 kg / arm		
Repeatability*1	±0.1 mm		
Range of Motion	R1	Rotation	-180° - +180°
		S-axis (lifting)	-180° - +180°
	R2	L-axis (lower arm)	-110° - +110°
		E-axis (elbow twist)	-170° - +170°
		U-axis (upper arm)	-130° - +130°
		R-axis (upper arm twist)	-180° - +180°
		B-axis (wrist pitch/yaw)	-110° - +110°
		T-axis (wrist twist)	-180° - +180°
Maximum Speed	R1	Rotation	2.18 rad/s, 125°/s
		S-axis (lifting)	2.27 rad/s, 130°/s
	R2	L-axis (lower arm)	2.27 rad/s, 130°/s
		E-axis (elbow twist)	2.97 rad/s, 170°/s
		U-axis (upper arm)	2.97 rad/s, 170°/s
		R-axis (upper arm twist)	3.49 rad/s, 200°/s
		B-axis (wrist pitch/yaw)	3.49 rad/s, 200°/s
		T-axis (wrist twist)	6.98 rad/s, 400°/s
Allowable Moment	R-axis (upper arm twist)	58.8 N · m	
	B-axis (wrist pitch/yaw)	58.8 N · m	
	T-axis (wrist twist)	29.4 N · m	
Allowable Inertia (GD ² /4)	R-axis (upper arm twist)	4.0 kg · m ²	
	B-axis (wrist pitch/yaw)	4.0 kg · m ²	
	T-axis (wrist twist)	2.0 kg · m ²	
Approx. Mass	380 kg		
Power Requirements*2	3.5 kVA*4		
Ambient Conditions	Temperature	0°C to +40°C	
	Humidity	20% to 80%RH (non-condensing)	
	Vibration	Less than 4.9 m/s ²	
Others	<ul style="list-style-type: none"> • Free from corrosive gas or liquid, or explosive gas or liquid • Free from exposure to water, oil or dust • Free from excessive electrical noise (plasma) 		

*1 : Conforms to ISO 9283.

*2 : Varies in accordance with applications and motion patterns.

*3 : The letter "F" at the end of the model number indicates that an FS100 controller is used to control the robot. When a DX100 controller is used, the model number will have the letter "D" at the end.

*4 : SDA20F requires 3.0 kVA

Note : SI units are used for the specifications.

7-axis Single-arm Robot

MOTOMAN-SIA5D/F

Single-arm

7 axes

Payload: 5 kg



The MOTOMAN-SIA5D/F features seven controlled axes with a 5 kg payload. Ideal for handling small objects in applications that require the robot to be installed in a limited space, and where a high level of positioning accuracy is needed.

Features

- High degree of motion like a human arm with its 7-axis arm.
- The arm has been slimmed by employing newly-developed miniaturized actuator for the wrist section, greatly reducing the interference of the arm with the workpiece.
- The maximum range of motion can be maintained using an ingenious mechanism for the arm joints that prevents the range of motion from being restricted even when downsizing robots.
- Light and weighs only 30 kg, so many installation choices are available: floor, ceiling, or wall.
- Environmental resistance: models with drip-proofing and for clean-room use are available.
 - Drip-proof protection level: IP65 for arm and IP54 for base. (Not acceptable to SIA5D/F flange at tip. A different model with a waterproof flange is available.)
 - Cleanliness level: ISO class 5 and complies with ISO 14644 standards when downflow of robot environment is 0.4 m/s or faster.

Notes : 1. Conduct a warming-up operation when the robot is to be used at low temperatures (10 degrees Celsius or lower).
2. Contact your Yaskawa representative for details.

- By utilizing internal user I/O wiring harness and air lines integrated in the arm, layout can be planned offline without worrying about peripheral interference. (Internal user I/O wiring harness and air lines specifications: two air lines and eight-core cables)
Note : External axis specification for a hand can be accommodated. Contact your Yaskawa representative regarding your requirements.

■ Dimensions Units: mm

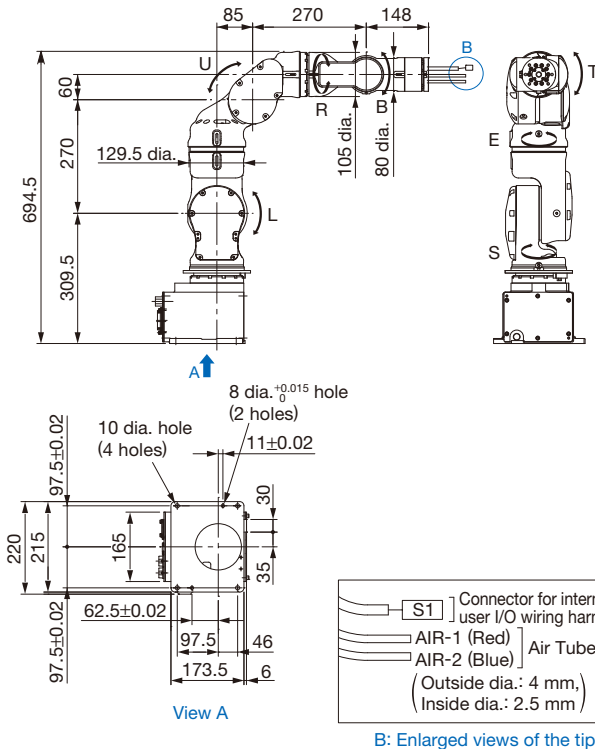

■ Manipulator Specifications

Model		MOTOMAN-SIA5D/F*3
Controlled Axis		7 (Vertically articulated)
Payload		5 kg
Repeatability*1		±0.06 mm
Range of Motion	S-axis (turning)	-180° - +180°
	L-axis (lower arm)	-110° - +110°
	E-axis (elbow twist)	-170° - +170°
	U-axis (upper arm)	-90° - +115°
	R-axis (wrist roll)	-180° - +180°
	B-axis (wrist pitch/yaw)	-110° - +110°
	T-axis (wrist twist)	-180° - +180°
Maximum Speed	S-axis (turning)	3.49 rad/s, 200°/s
	L-axis (lower arm)	3.49 rad/s, 200°/s
	E-axis (elbow twist)	3.49 rad/s, 200°/s
	U-axis (upper arm)	3.49 rad/s, 200°/s
	R-axis (wrist roll)	3.49 rad/s, 200°/s
	B-axis (wrist pitch/yaw)	4.01 rad/s, 230°/s
	T-axis (wrist twist)	6.11 rad/s, 350°/s
Allowable Moment	R-axis (wrist roll)	14.7 N · m
	B-axis (wrist pitch/yaw)	14.7 N · m
	T-axis (wrist twist)	7.35 N · m
Allowable Inertia (GD ² /4)	R-axis (wrist roll)	0.45 kg · m ²
	B-axis (wrist pitch/yaw)	0.45 kg · m ²
	T-axis (wrist twist)	0.11 kg · m ²
Approx. Mass		30 kg
Power Requirements*2		1.0 kVA
Ambient Conditions	Temperature	0°C to +40°C
	Humidity	20% to 80%RH (non-condensing)
	Vibration	Less than 4.9 m/s ²
	Others	<ul style="list-style-type: none"> • Free from corrosive gas or liquid, or explosive gas or liquid • Free from exposure to water, oil or dust • Free from excessive electrical noise (plasma)

*1 : Conforms to ISO 9283.

*2 : Varies in accordance with applications and motion patterns.

*3 : The letter "F" at the end of the model number indicates that an FS100 controller is used to control the robot. When a DX100 controller is used, the model number will have the letter "D" at the end.

Note : SI units are used for the specifications.

7-axis Single-arm Robot

MOTOMAN-SIA10D/F

Single-arm

7 axes

Payload: 10 kg



The MOTOMAN-SIA10D/F is a robot with seven controlled axes and a 10 kg payload that is more compact than the SIA20D/F.

Optimal for handling small objects in limited space.

Features

- High degree of motion like a human arm with its 7-axis arm.
- The high flexibility of motion makes operation possible even in narrow spaces that are inaccessible to humans.
- Folds to compact size when not in use.
- Many installation options: on the floor, wall, ceiling, or slope
- Optimal for handling small objects.
- Environmental resistance: models with drip-proofing and for clean-room use are available.
 - Drip-proof protection level: IP65 for arm and IP54 for base. (Not acceptable to SIA10D/F flange at tip. A different model with a waterproof flange is available.)
 - Cleanliness level: ISO class 5 and complies with ISO 14644 standards when downflow of robot environment is 0.4 m/s or faster.

Notes : 1. Conduct a warming-up operation when the robot is to be used at low temperatures (10 degrees Celsius or lower).
2. Contact your Yaskawa representative for details.

- By utilizing internal user I/O wiring harness and air lines integrated in the arm, layout can be planned offline without worrying about peripheral interference. (Internal user I/O wiring harness and air lines specifications: two air hoses and twelve-core cables)

Note : External axis specification for a hand can be accommodated. Contact your Yaskawa representative regarding your requirements.

Dimensions Units: mm

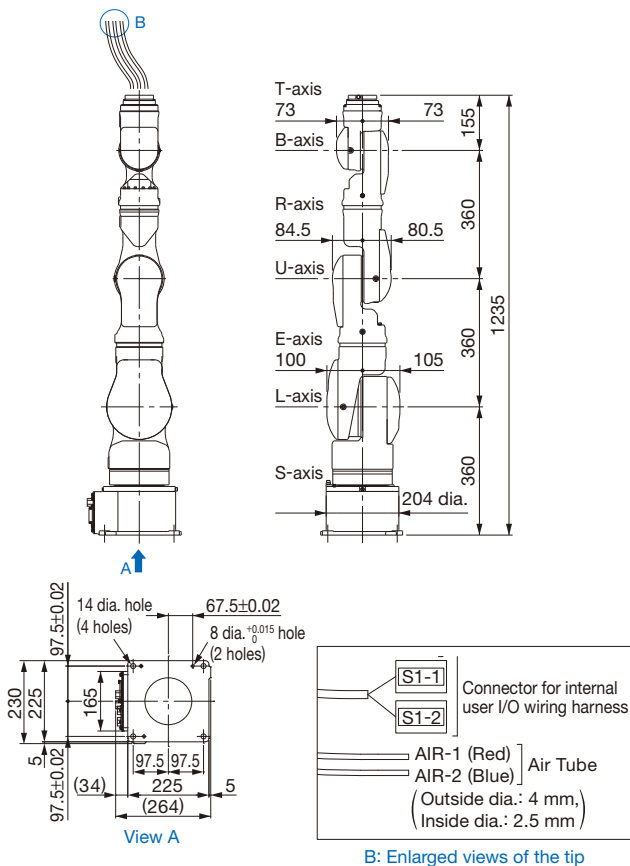

Manipulator Specifications

Model		MOTOMAN-SIA10D/F*3
Controlled Axis		7 (Vertically articulated)
Payload		10 kg
Repeatability*1		±0.1 mm
Range of Motion	S-axis (turning)	-180° - +180°
	L-axis (lower arm)	-110° - +110°
	E-axis (elbow twist)	-170° - +170°
	U-axis (upper arm)	-135° - +135°
	R-axis (wrist roll)	-180° - +180°
	B-axis (wrist pitch/yaw)	-110° - +110°
	T-axis (wrist twist)	-180° - +180°
Maximum Speed	S-axis (turning)	2.97 rad/s, 170°/s
	L-axis (lower arm)	2.97 rad/s, 170°/s
	E-axis (elbow twist)	2.97 rad/s, 170°/s
	U-axis (upper arm)	2.97 rad/s, 170°/s
	R-axis (wrist roll)	3.49 rad/s, 200°/s
	B-axis (wrist pitch/yaw)	3.49 rad/s, 200°/s
	T-axis (wrist twist)	6.98 rad/s, 400°/s
Allowable Moment	R-axis (wrist roll)	31.4 N · m
	B-axis (wrist pitch/yaw)	31.4 N · m
	T-axis (wrist twist)	19.6 N · m
Allowable Inertia (GD ² /4)	R-axis (wrist roll)	1.0 kg · m ²
	B-axis (wrist pitch/yaw)	1.0 kg · m ²
	T-axis (wrist twist)	0.4 kg · m ²
Approx. Mass		60 kg
Power Requirements*2		1.5 kVA*4
Ambient Conditions	Temperature	0°C to +40°C
	Humidity	20% to 80%RH(non-condensing)
	Vibration	Less than 4.9 m/s ²
	Others	<ul style="list-style-type: none"> • Free from corrosive gas or liquid, or explosive gas or liquid • Free from exposure to water, oil or dust • Free from excessive electrical noise (plasma)

*1 : Conforms to ISO 9283.

*2 : Varies in accordance with applications and motion patterns.

*3 : The letter "F" at the end of the model number indicates that an FS100 controller is used to control the robot. When a DX100 controller is used, the model number will have the letter "D" at the end.

*4 : SIA10F requires 1.0 kVA.

Note : SI units are used for the specifications.

MOTOMAN-SIA20D/F

Single-arm

7 axes

Payload: 20 kg



A built-in crystal sensor type is also available
For details, refer to the KAEP C940440 26 catalog

With its unique arm form and seven controlled axes, the space-saving MOTOMAN-SIA20D/F has achieved flexibility of movement that was impossible for robots till now. This model is capable of handling heavy objects up to 20kg.

Features

- High degree of motion like a human arm with its 7-axis arm.
- The high flexibility of motion makes operation possible even in narrow spaces inaccessible to humans.
- Folds to compact size when not in use.
- Many installation options: on the floor, wall, ceiling, or slope
- Assembles and handles heavy objects up to 20 kg.
- Environmental resistance: models with drip-proofing and for clean-room use are available.
 - Drip-proof protection level: IP65 for arm and IP54 for base.(Not acceptable to SIA20D/F flange at tip. A different model with a waterproof flange is available.)
 - Cleanness level: ISO class 5 and complies with ISO 14644 standards when downflow of robot environment is 0.4 m/s or faster.

Notes : 1. Conduct a warming-up operation when the robot is to be used at low temperatures (10 degrees Celsius or lower).
2. Contact your Yaskawa representative for details.

- By utilizing internal user I/O wiring harness and air lines integrated in the arm, layout can be planned offline without worrying about peripheral interference.
(Internal user I/O wiring harness and air lines specifications: two air hoses and sixteen-core cables)

Note : External axis specification for a hand can be accommodated. Contact your Yaskawa representative regarding your requirements.

Dimensions Units: mm

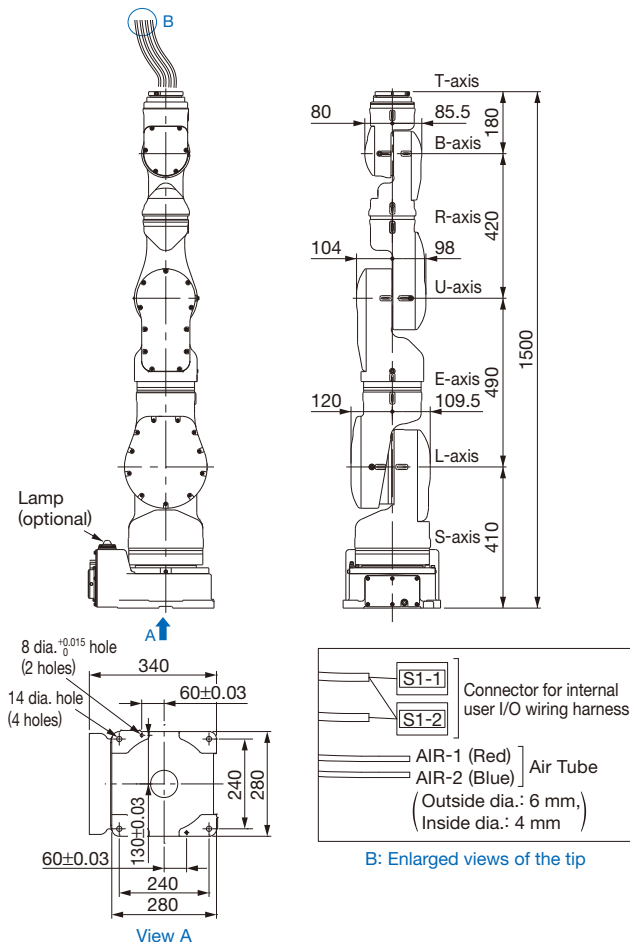

Manipulator Specifications

Model	MOTOMAN-SIA20D/F*3	
Controlled Axis	7 (Vertically articulated)	
Payload	20 kg	
Repeatability*1	±0.1 mm	
Range of Motion	S-axis (turning)	-180° - +180°
	L-axis (lower arm)	-110° - +110°
	E-axis (elbow twist)	-170° - +170°
	U-axis (upper arm)	-130° - +130°
	R-axis (wrist roll)	-180° - +180°
	B-axis (wrist pitch/yaw)	-110° - +110°
	T-axis (wrist twist)	-180° - +180°
Maximum Speed	S-axis (turning)	2.27 rad/s, 130°/s
	L-axis (lower arm)	2.27 rad/s, 130°/s
	E-axis (elbow twist)	2.97 rad/s, 170°/s
	U-axis (upper arm)	2.97 rad/s, 170°/s
	R-axis (wrist roll)	3.49 rad/s, 200°/s
	B-axis (wrist pitch/yaw)	3.49 rad/s, 200°/s
	T-axis (wrist twist)	6.98 rad/s, 400°/s
Allowable Moment	R-axis (wrist roll)	58.8 N · m
	B-axis (wrist pitch/yaw)	58.8 N · m
	T-axis (wrist twist)	29.4 N · m
Allowable Inertia (GD ² /4)	R-axis (wrist roll)	4.0 kg · m ²
	B-axis (wrist pitch/yaw)	4.0 kg · m ²
	T-axis (wrist twist)	2.0 kg · m ²
Approx. Mass	120 kg	
Power Requirements*2	2.0 kVA*4	
Ambient Conditions	Temperature	0°C to +40°C
	Humidity	20% to 80%RH(non-condensing)
	Vibration	Less than 4.9 m/s ²
	Others	<ul style="list-style-type: none"> • Free from corrosive gas or liquid, or explosive gas or liquid • Free from exposure to water, oil or dust • Free from excessive electrical noise (plasma)

* 1 : Conforms to ISO 9283.

* 2 : Varies in accordance with applications and motion patterns.

* 3 : The letter "F" at the end of the model number indicates that an FS100 controller is used to control the robot. When a DX100 controller is used, the model number will have the letter "D" at the end.

* 4 : SIA20F requires 1.5 kVA.

Note : SI units are used for the specifications.

7-axis Single-arm Robot

MOTOMAN-SIA30D

Single-arm

7 axes

Payload: 30 kg



The MOTOMAN-SIA30D features seven controlled axes with a 30 kg payload. The wide range of motion and flexible movement expand the possible range of applications.

Features

- High degree of motion like a human arm with its 7-axis arm.
- High-speed and high-precision operation.
- Folds to compact size when not in use.
- Assembles and handles heavy objects up to 30 kg.
- Many installation options: on the floor, wall, ceiling, or slope
- Environmental resistance: model with drip-proofing is available. Protection level: IP65 for arm and IP54 for base. (Not acceptable to SIA30D flange at tip. A different model with a waterproof flange is available.)
Notes : 1. Conduct a warming-up operation when the robot is to be used at low temperatures (10 degrees Celsius or lower).
2. Contact your Yaskawa representative for details.
- By utilizing internal user I/O wiring harness and air lines integrated in the arm, layout can be planned offline without worrying about peripheral interference. (Internal user I/O wiring harness and air lines specifications: two air hoses and eight-core cables)
Note : External axis specification for a hand can be accommodated. Contact your Yaskawa representative regarding your requirements.

Dimensions Units: mm

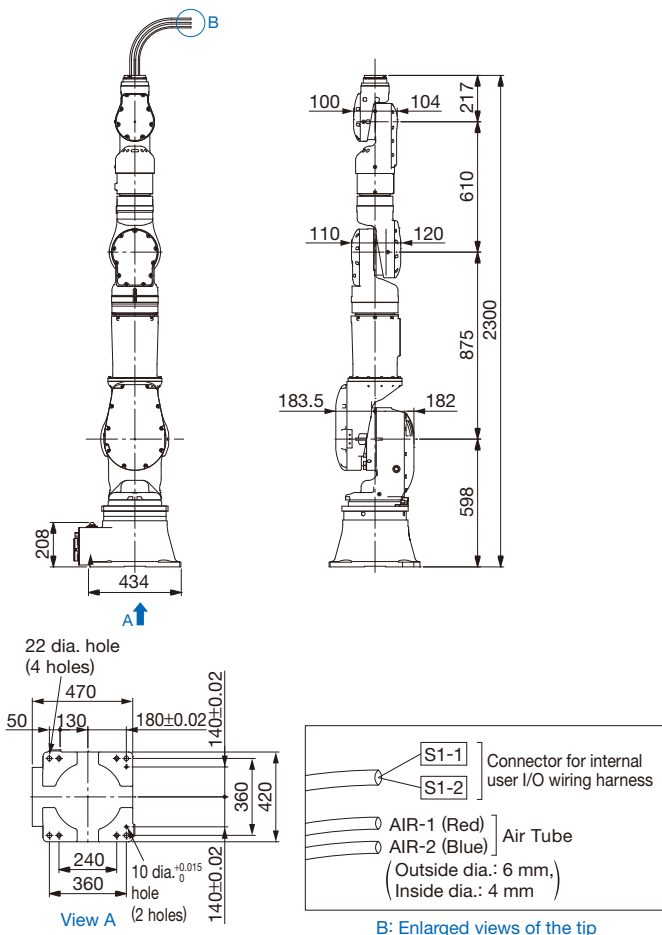

Manipulator Specifications

Model	MOTOMAN-SIA30D	
Controlled Axis	7 (Vertically articulated)	
Payload	30 kg	
Repeatability*1	±0.1 mm	
Range of Motion	S-axis (turning)	-180° - +180°
	L-axis (lower arm)	-125° - +125°
	E-axis (elbow twist)	-170° - +170°
	U-axis (upper arm)	-110° - +110°
	R-axis (wrist roll)	-170° - +170°
	B-axis (wrist pitch/yaw)	-110° - +110°
	T-axis (wrist twist)	-180° - +180°
Maximum Speed	S-axis (turning)	2.27 rad/s, 130°/s
	L-axis (lower arm)	2.27 rad/s, 130°/s
	E-axis (elbow twist)	2.27 rad/s, 130°/s
	U-axis (upper arm)	2.27 rad/s, 130°/s
	R-axis (wrist roll)	2.97 rad/s, 170°/s
	B-axis (wrist pitch/yaw)	2.97 rad/s, 170°/s
	T-axis (wrist twist)	3.49 rad/s, 200°/s
Allowable Moment	R-axis (wrist roll)	117.6 N · m
	B-axis (wrist pitch/yaw)	117.6 N · m
	T-axis (wrist twist)	58.8 N · m
Allowable Inertia (GD ² /4)	R-axis (wrist roll)	6.0 kg · m ²
	B-axis (wrist pitch/yaw)	6.0 kg · m ²
	T-axis (wrist twist)	3.0 kg · m ²
Approx. Mass	345 kg	
Power Requirements*2	Temperature	0°C to +40°C
	Humidity	20% to 80%RH(non-condensing)
	Vibration	Less than 4.9 m/s ²
Ambient Conditions	Others	<ul style="list-style-type: none"> • Free from corrosive gas or liquid, or explosive gas or liquid • Free from exposure to water, oil or dust • Free from excessive electrical noise (plasma)

*1 : Conforms to ISO 9283.
*2 : Varies in accordance with applications and motion patterns.
Note : SI units are used for the specifications.

MOTOMAN-SIA50D

Single-arm

7 axes

Payload: 50 kg



The MOTOMAN-SIA50D is a robot with seven controlled axes and is capable of handling heavy objects up to 50 kg. Optimal for handling heavy objects in limited spaces.

Features

- High degree of motion like a human arm with its 7-axis arm.
- High-speed and high-precision operation.
- Folds to compact size when not in use.
- Assembles and handles heavy objects up to 50 kg.
- Many installation options: on the floor, wall, ceiling, or slope
- Environmental resistance: model with drip-proofing is available. Protection level: IP65 for arm and IP54 for base. (Not acceptable to SIA50D flange at tip. A different model with a waterproof flange is available.)
Notes : 1. Conduct a warming-up operation when the robot is to be used at low temperatures (10 degrees Celsius or lower).
2. Contact your Yaskawa representative for details.
- By utilizing internal user I/O wiring harness and air lines integrated in the arm, layout can be planned offline without worrying about peripheral interference. (Internal user I/O wiring harness and air lines specifications: two air hoses and twenty four-core cables)
Note : External axis specification for a hand can be accommodated. Contact your Yaskawa representative regarding your requirements.

Dimensions Units: mm

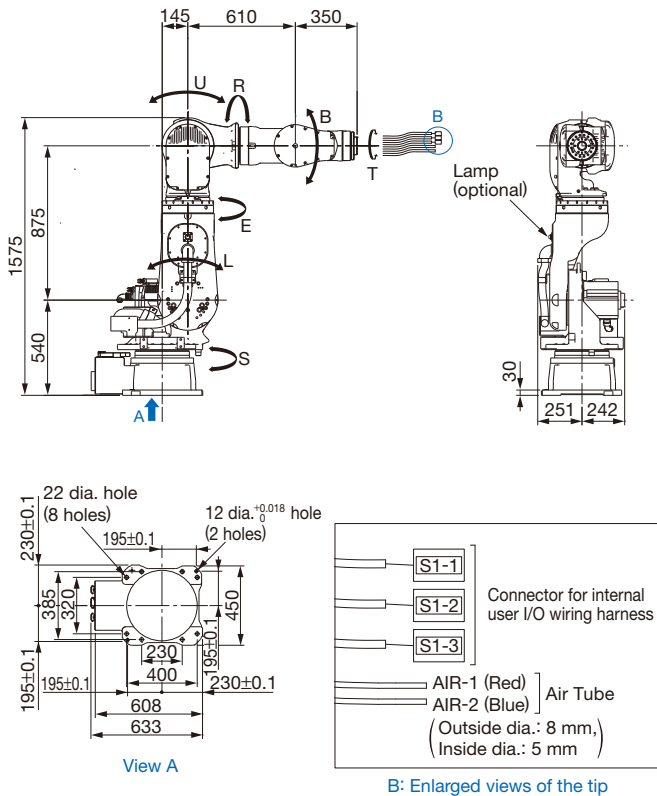

Manipulator Specifications

Model	MOTOMAN-SIA50D	
Controlled Axis	7 (Vertically articulated)	
Payload	50 kg	
Repeatability*1	±0.1 mm	
Range of Motion	S-axis (turning)	-180° - +180°
	L-axis (lower arm)	-60° - +125°
	E-axis (elbow twist)	-170° - +170°
	U-axis (upper arm)	-35° - +215°
	R-axis (wrist roll)	-170° - +170°
	B-axis (wrist pitch/yaw)	-125° - +125°
	T-axis (wrist twist)	-180° - +180°
Maximum Speed	S-axis (turning)	2.97 rad/s, 170°/s
	L-axis (lower arm)	2.27 rad/s, 130°/s
	E-axis (elbow twist)	2.27 rad/s, 130°/s
	U-axis (upper arm)	2.27 rad/s, 130°/s
	R-axis (wrist roll)	2.27 rad/s, 130°/s
	B-axis (wrist pitch/yaw)	2.27 rad/s, 130°/s
	T-axis (wrist twist)	3.49 rad/s, 200°/s
Allowable Moment	R-axis (wrist roll)	377 N · m
	B-axis (wrist pitch/yaw)	377 N · m
	T-axis (wrist twist)	147 N · m
Allowable Inertia (GD ² /4)	R-axis (wrist roll)	29.6 kg · m ²
	B-axis (wrist pitch/yaw)	29.6 kg · m ²
	T-axis (wrist twist)	12.5 kg · m ²
	Approx. Mass	640 kg
Power Requirements*2	5.0 kVA	
Ambient Conditions	Temperature	0°C to +40°C
	Humidity	20% to 80%RH(non-condensing)
	Vibration	Less than 4.9 m/s ²
	Others	<ul style="list-style-type: none"> • Free from corrosive gas or liquid, or explosive gas or liquid • Free from exposure to water, oil or dust • Free from excessive electrical noise (plasma)

* 1 : Conforms to ISO 9283.

* 2 : Varies in accordance with applications and motion patterns.

Note : SI units are used for the specifications.

MOTOMAN-SDA, SIA Series

Controller Specifications

Items	DX100 Controller	FS100 Controller
Configuration	Dust proof	IP20 (open structure)
Dimensions (W)×(D)×(H), Mass	MOTOMAN-SDA5D, SDA10D, SDA20D : 500×580×880 mm, 150 kg max.(Possible to control 1 external axis.)	MOTOMAN-SDA5F, SDA10F, SDA20F : 470×475×420 mm (includes projecting parts.) 40 kg, (Possible to control 1 external axis.)
	MOTOMAN-SIA5D, SIA10D, SIA20D : 500×580×580 mm, 100 kg max.(Possible to control 1 external axis.)	MOTOMAN-SIA5F, SIA10F, SIA20F : 470×475×210 mm (includes projecting parts.) 20 kg, (Possible to control 1 external axis.)
	MOTOMAN-SIA30D, SIA50D : 425×450×1200 mm, 100 kg max.(Possible to control 2 external axes.)	
Cooling System	Indirect cooling	Direct cooling
Ambient Temperature	During operation : 0°C to +45°C During storage : -10°C to +60°C	During operation : 0°C to +40°C During storage : -10°C to +60°C
Relative Humidity	90% max. (non-condensing)	90% max. (non-condensing)
Power Supply	Three-phase 200/220 VAC (+10% to -15%), 60 Hz (±2%)(Japan) Three-phase 200 VAC (+10% to -15%), 50 Hz (±2%)(Japan)	Three-phase 200/220 VAC (+10%, -15%), 50/60 Hz Single-phase 200/230 VAC (+10%, -15%), 50/60 Hz
Grounding	Grounding resistance : 100 Ω or less	Grounding resistance : 100 Ω or less
Digital I/Os	Specialized signals : 23 inputs and 5 outputs General signals : 40 inputs and 40 outputs Max. I/O (optional) : 2,048 inputs and 2,048 outputs	Specialized signals : 19 inputs and 2 outputs General signals : 28 inputs and 28 outputs Max. I/O (optional) : 1,024 inputs and 1,024 outputs
Positioning System	Serial communications (absolute encoder)	Serial communications (absolute encoder)
Programming Capacity	JOB : 200,000 steps, 10,000 instructions CIO ladder : 20,000 steps	JOB : 10,000 steps, 1,000 instructions CIO ladder : 1,500 steps
Expansion Slots	PCI : 2 slots for main CPUs and 1 slot for servo CPU 1 additional slot for sensor board	MP2000 bus×5 slots
LAN (Connection to Host)	1(10BASE-T/100BASE-TX)	1(10BASE-T/100BASE-TX)
Interface	RS-232C : 1ch	RS-232C : 1ch
Control Method	Software servo control	Software servo control
Drive Units	SERVOPACK for AC servomotors (can be controlled up to 8 axes)	Standard 6 axes and 1 additional single-axis amplifiers can be mounted.
Items	Programming Pendant *	
Dimensions	169(W) × 50(D) × 314.5(H) mm	
Mass	0.990 kg	
Material	Reinforced plastics	
Operation	Select keys, axis keys(8 axes), numerical/application keys, Mode switch with key (mode : teach, play, and remote), emergency stop button, enable switch, compact flash card interface device (compact flash is optional.), USB port (1 port)	
Display	640 × 480 pixels color LCD, touch panel (Alphanumeric characters, Chinese characters, Japanese letters, Others)	
IEC Protection Class	IP65	
Cable Length	Standard : 8 m, Max. : 36 m (optional)	Standard : 8 m, optional : 20 m max.

*: The programming pendant for the FS100 controller is optional. The model number of the programming pendant differs from that of the programming pendant for the DX100 controller.

Sales Department

HEAD OFFICE

2-1 Kurosaki-Shiroishi, Yahatanishi-ku, Kitakyushu, Fukuoka 806-0004, Japan
Phone: +81-93-645-7703 Fax: +81-93-645-7802

YASKAWA America, Inc. (Motoman Robotics Division)

100 Automation Way, Miamisburg, OH 45342, U.S.A.
Phone: +1-937-847-6200 Fax: +1-937-847-6277

YASKAWA Europe GmbH (Robotics Division)

Yaskawastrasse 1, 85391, Allershausen, Germany
Phone: +49-8166-90-100 Fax: +49-8166-90-103

YASKAWA Nordic AB

Verkstadsгатan 2, Box 504, SE-385 25 Torsas, Sweden
Phone: +46-480-417-800 Fax: +46-486-414-10

YASKAWA Electric (China) Co., Ltd.

22F, One Corporate Avenue, No.222 Hubin Road, Huangpu District, Shanghai 200021, China
Phone: +86-21-5385-2200 Fax: +86-21-5385-3299

YASKAWA SHOUGANG ROBOT CO., LTD.

No.7 Yongchang North Road, Beijing E&T Development Area China 100176
Phone: +86-10-6788-2858 Fax: +86-10-6788-2878

YASKAWA India Private Ltd. (Robotics Division)

#426, Udyog Vihar Phase-IV, Gurgaon, Haryana, India
Phone: +91-124-475-8500 Fax: +91-124-475-8542

YASKAWA Electric Korea Corporation

35F, Three IFC, 10 Gukjegeumyung-ro, Yeongdeungpo-gu, Seoul, Korea 07326
Phone: +82-2-784-7844 Fax: +82-2-784-8495

YASKAWA Electric Taiwan Corporation

12F, No.207, Sec. 3, Beishin Rd., Shindian District, New Taipei City 23143, Taiwan
Phone: +886-2-8913-1333 Fax: +886-2-8913-1513

YASKAWA Electric (Singapore) PTE Ltd

151 Lorong Chuan, #04-02A New Tech Park, Singapore 556741
Phone: +65-6282-3003 Fax: +65-6289-3003

YASKAWA Electric (Thailand) Co., Ltd.

59, 1st-5th Floor, Flourish Building, Soi Ratchadapisek 18, Ratchadapisek Road, Huaykwang, Bangkok 10310, Thailand
Phone: +66-2-017-0099 Fax: +66-2-017-0199

PT. YASKAWA Electric Indonesia

Secure Building-Gedung B Lantai Dasar & Lantai 1 Jl. Raya Protokol Halim Perdanakusuma, Jakarta 13610, Indonesia
Phone: +62-21-2982-6470 Fax: +62-21-2982-6471

YASKAWA

YASKAWA ELECTRIC CORPORATION

In the event that the end user of this product is to be the military and said product is to be employed in any weapons systems or the manufacture thereof, the export will fall under the relevant regulations as stipulated in the Foreign Exchange and Foreign Trade Regulations. Therefore, be sure to follow all procedures and submit all relevant documentation according to any and all rules, regulations and laws that may apply. Specifications are subject to change without notice for ongoing product modifications and improvements.

© 2008 YASKAWA ELECTRIC CORPORATION

LITERATURE NO. KAEP C940440 18E <5>-0

Published in Japan August 2017

16-8-43